

Clamp Crane CB3-6 (for Sheet Piles)

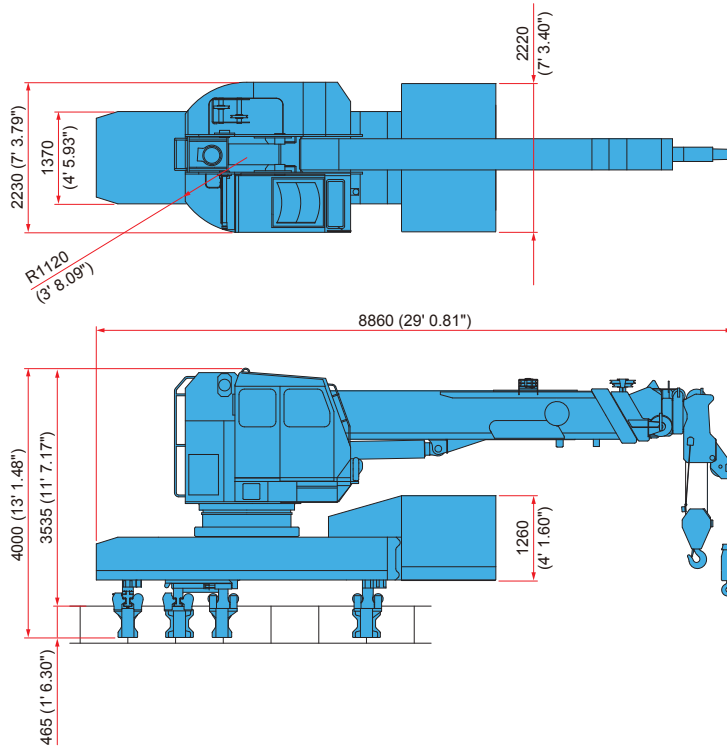

CB3-6	Metric Unit	US Standard
Applicable Reaction Piles	400 - 900 mm	15.74 - 35.43 in
Lifting Capacity	10000 kg x 6.5 m	22046 lb x 21.32 ft
Max. Working Radius	30.0 m	98.42 ft
Crane Operation	Manual	
Movement on Piles	Self-moving	
Self-moving Operation	Radio Control	
Power Source	Diesel Engine	
Rated Output	63.9 kW	85 HP
Mass	24900 kg	54895 lb

Specifications are subject to alteration without prior notice.